

MSC-07RV -E1 (WH) MSC-07RV -E2 (WH) MSC-07RV -E3 (WH) MSC-07RV -E4 (WH)
 MSC-09RV -E1 (WH) MSC-09RV -E2 (WH) MSC-09RV -E3 (WH) MSC-09RV -E4 (WH)
 MSC-12RV -E1 (WH) MSC-12RV -E2 (WH) MSC-12RV -E3 (WH) MSC-12RV -E4 (WH)

8-3. COMPONENTES ELÉCTRICOS Y FUNCIONALES UN. INTERIOR

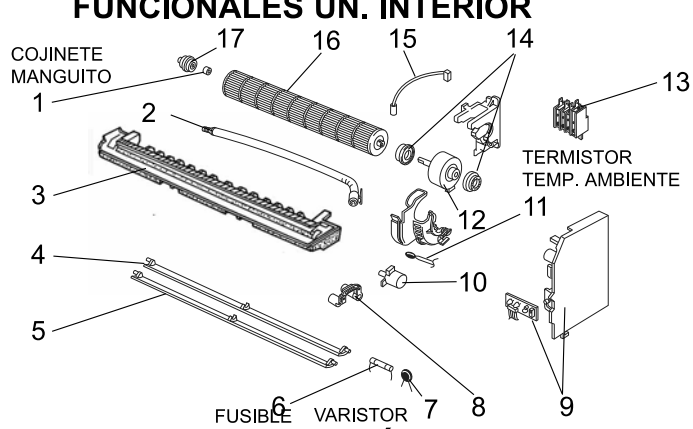

8-4. INTERCAMBIADOR CALOR UN. INT.

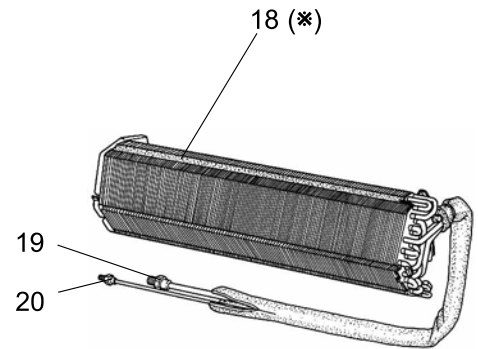

(*)Estas cifras indican MSC-12RV.

8-3. COMPONENTES ELÉCTRICOS Y FUNCIONALES UNIDAD INTERIOR

No.	Nº comp.	Nombre comp.	Símbolo Diagrama conex.	Cant./unidad												Observac.
				MSC-07RV				MSC-09RV				MSC-12RV				
				E1 (WH)	E2 (WH)	E3 (WH)	E4 (WH)	E1 (WH)	E2 (WH)	E3 (WH)	E4 (WH)	E1 (WH)	E2 (WH)	E3 (WH)	E4 (WH)	
1	E02 001 504	SLEEVE BEARING		1	1	1	1	1	1	1	1	1	1	1	1	
2	E02 408 702	DRAIN HOSE		1	1	1	1	1	1	1	1	1	1	1	1	
3	E02 409 235	NOZZLE (WH)		1	1	1	1	1	1	1	1	1	1	1	1	
4	E02 409 040	VANE UPPER (WH)		1	1	1	1	1	1	1	1	1	1	1	1	
5	E02 409 041	VANE LOWER (WH)		1	1	1	1	1	1	1	1	1	1	1	1	
6	E02 127 382	FUSE	F11	1	1	1	1	1	1	1	1	1	1	1	1	3.15A
7	E02 336 385	VARISTOR	NR11	1	1	1	1	1	1	1	1	1	1	1	1	
8	E02 408 034	VANE MOTOR SUPPORT SET		1	1	1	1	1	1	1	1	1	1	1	1	
9	E02 424 452	ELECTRONIC CONTROL P.C.BOARD		1												AUTO RESTART
	E02 504 452	ELECTRONIC CONTROL P.C.BOARD			1											AUTO RESTART
	E02 583 452	ELECTRONIC CONTROL P.C.BOARD				1										AUTO RESTART
	E02 691 452	ELECTRONIC CONTROL P.C.BOARD					1									AUTO RESTART
	E02 425 452	ELECTRONIC CONTROL P.C.BOARD						1								AUTO RESTART
	E02 505 452	ELECTRONIC CONTROL P.C.BOARD							1							AUTO RESTART
	E02 584 452	ELECTRONIC CONTROL P.C.BOARD								1						AUTO RESTART
	E02 692 452	ELECTRONIC CONTROL P.C.BOARD									1					AUTO RESTART
	E02 426 452	ELECTRONIC CONTROL P.C.BOARD										1				AUTO RESTART
10	E02 408 303	VANE MOTOR	MV	1	1	1	1	1	1	1	1	1	1	1	1	
	E02 693 303	VANE MOTOR	MV												1	
11	E02 408 308	ROOM TEMPERATURE THERMISTOR	RT11	1	1	1	1	1	1	1	1	1	1	1	1	
12	E02 151 300	INDOOR FAN MOTOR	MF	1	1	1		1	1	1		1	1	1	1	RC4V19-□□
	E02 665 300	INDOOR FAN MOTOR	MF				1				1					RC4V19-□□
13	E02 424 375	TERMINAL BLOCK	TB	1	1	1		1	1	1		1	1	1		
	E02 691 375	TERMINAL BLOCK	TB				1				1				1	
14	E02 151 505	FAN MOTOR RUBBER MOUNT		2	2	2		2	2	2		2	2	2	2	2PCS/SET
	E02 665 505	FAN MOTOR RUBBER MOUNT					2				2					2PCS/SET
15	E02 408 307	INDOOR COIL THERMISTOR	RT12	1	1	1	1	1	1	1	1	1	1	1	1	
16	E02 408 302	LINE FLOW FAN		1	1	1	1	1	1	1	1	1	1	1	1	
17	E02 408 509	BEARING MOUNT		1	1	1	1	1	1	1	1	1	1	1	1	

8-4. INTERCAMBIADOR CALOR UNIDAD INTERIOR

18	E02 408 620	INDOOR HEAT EXCHANGER		1	1	1	1	1	1	1						
	E02 410 620	INDOOR HEAT EXCHANGER										1				
	E02 515 620	INDOOR HEAT EXCHANGER											1	1	1	
19	E02 151 666	UNION(GAS)		1	1	1	1	1	1	1						φ9.52
	E02 155 666	UNION(GAS)										1	1	1	1	φ12.7
20	E02 151 667	UNION(LIQUID)		1	1	1	1	1	1	1	1	1	1	1	1	φ6.35